

Product Datasheet

800G OSFP SR8 Transceiver

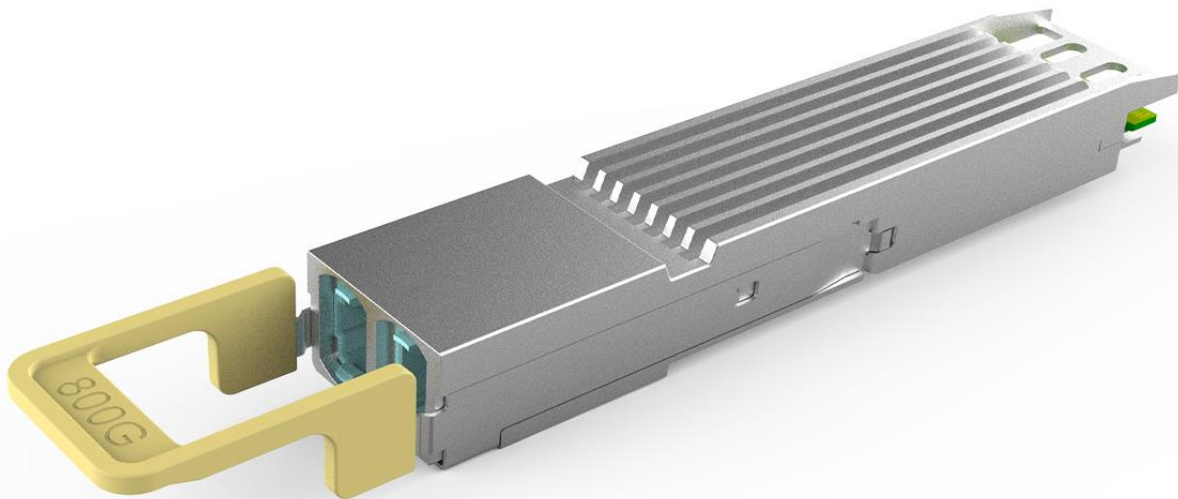

Application

- Data center & Networking Equipment
- Servers/Storage Devices
- High Performance Computing (HPC)
- Switches/Routers
- Telecom Central Offices (CO)
- Test and Measurement Equipment

Features

- Hot-pluggable OSFP 800G SR8 multimode transceiver
- Compliant with OSFP MSA Type2 flat top with dual MPO-12 connector
- Compliant with CMIS Rev 5.0 and above revision
- Maximum power consumption 17W
- Dual MPO-12 APC receptacles
- Up to 30m reach on OM3 and 50m on OM4
- Case operating temperature 0°C to 70°C

1.0 Product Specification

1.1 Absolute Maximum Ratings (TC=25°C, unless otherwise noted)

Stresses in excess of the absolute maximum ratings can cause permanent damage to the device. These are absolute stress ratings only. Functional operation of the device is not implied at these or any other conditions in excess of those given in the operational sections of the data sheet. Exposure to absolute maximum ratings will cause permanent damage and/or adversely affect device reliability.

Parameter	Symbol	Min	Typical	Max	Unit	Notes
Storage Temperature	TS	-40	-	+85	°C	
Maximum Supply Voltage	V _{CC}	-0.5	-	3.6	V	
Operating Relative Humidity	RH	5	-	95	%	No condensation
Control Input Voltage	V _I	-0.3	-	V _{CC} +0.5	V	

1.2 General Specifications (TC=25°C, unless otherwise noted)

Parameter	Symbol	Min	Typical	Max	Unit	Notes
Operating Case Temperature	T _{OPR}	0	-	70	°C	
Power Supply Voltage	V _{CC}	3.135	3.3	3.465	V	
Instantaneous peak current at hot plug	I _{CC_IP}	-	-	6800	mA	
Sustained peak current at hot plug	I _{CC_SP}	-	-	5670	mA	
Maximum Power Dissipation	P _D	-	-	17	W	
Maximum Power Dissipation, Low Power Mode	P _{DLP}	-	-	1.5	W	
Signaling Rate per Lane	SRL	-	53.125	-	GBd	PAM4
Two Wire Serial Interface Clock Rate	-	-100	-	1000	kHz	
Power Supply Noise Tolerance (10Hz - 10MHz)	-	-	-	66	mV	
Rx Differential Data Output Load	-	-	100	-	Ohm	
Operating Distance (OM3)	-	2	-	30	m	
Operating Distance (OM4)	-	2	-	50	m	

1.3 Transmitter Characteristics (TC=25°C, unless otherwise noted)

Parameter	Symbol	Min	Typical	Max	Unit	Notes
Wavelength	λ_c	844	850	863	nm	
RMS spectral width	$\Delta\lambda_{rms}$			0.6	nm	
Average Launch Power, each lane	AOP _L	-1.0	-	3.0	dBm	1
Outer Optical Modulation Amplitude (OMA _{outer}), each lane	T _{OMA}	-2.1		3.5	dBm	2
Transmitter and Dispersion Eye Closure for PAM4 (TDECQ), each lane	TDECQ	-	-	4.4	dB	
Average Launch Power of OFF Transmitter, each lane	T _{OFF}	-	-	-30	dBm	
Extinction Ratio, each lane	ER	2.5	3.5	-	dB	
RIN _{14OMA}	RIN	-	-	-148	dB/Hz	
Optical Return Loss Tolerance	ORL		-	14	dB	
Transmitter Reflectance	T _R	-	-	-26	dB	3

Notes

1. Average launch power, each lane (min) is informative and not the principal indicator of signal strength.
2. Even if max (TECQ, TDECQ) < 1.8dB, OMA_{outer} (min) must exceed this value.
3. Transmitter reflectance is defined looking into the transmitter.

1.4 Receiver Characteristics (TC=25°C, unless otherwise noted)

Parameter	Symbol	Min	Typical	Max	Unit	Notes
Wavelength	λ_c	842	850	863	nm	
Damage Threshold, average optical power, each lane	AOP _D	5	-	-	dBm	
Average Receive Power, each lane	AOP _R	-6.3	-	4.0	dBm	
Receive Power (OMA _{outer}), each lane	OMA _R	-	-	3.5	dBm	
Receiver Reflectance	RR	-	-	-20	dB	
Receiver Sensitivity (OMA _{outer}), each lane	S _{OMA}	-	-	-4.6	dBm	1
Stressed Receiver Sensitivity (OMA _{outer}), each lane	SRS	-	-	-2.0	dBm	2
Conditions of stressed receiver sensitivity test						

Stressed eye closure for PAM4	SECQ		4.4		dB	
OMA _{outer} of each aggressor lane	OMA _{outer}		3.5		dBm	

Notes

1. Receiver sensitivity (OMA_{outer}), each lane (max) is informative and is defined for a transmitter with TDECQ≤1.8 dB
2. Measured with conformance test signal at TP3 for the BER = 2.4x10⁻⁴

1.5 PIN Descriptions

Top Side (viewed from top)

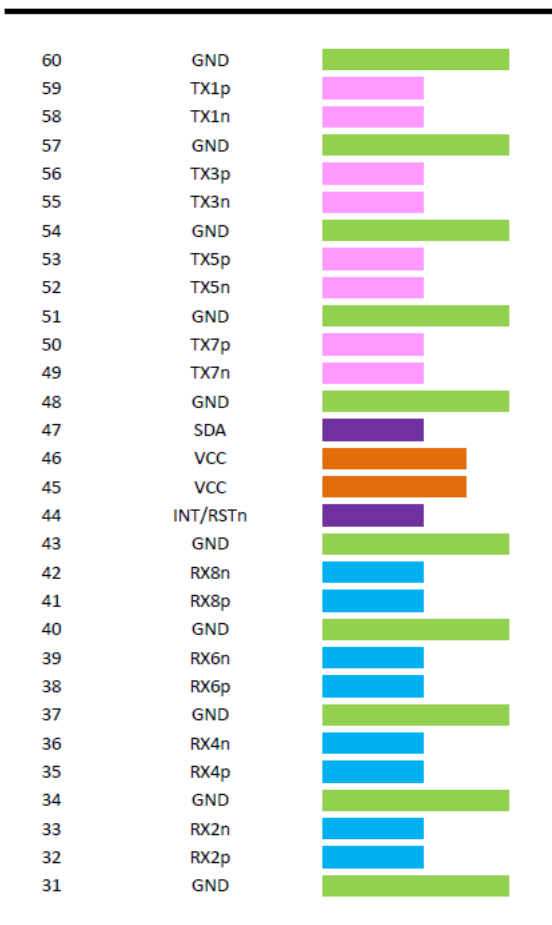

Bottom Side (viewed from bottom)

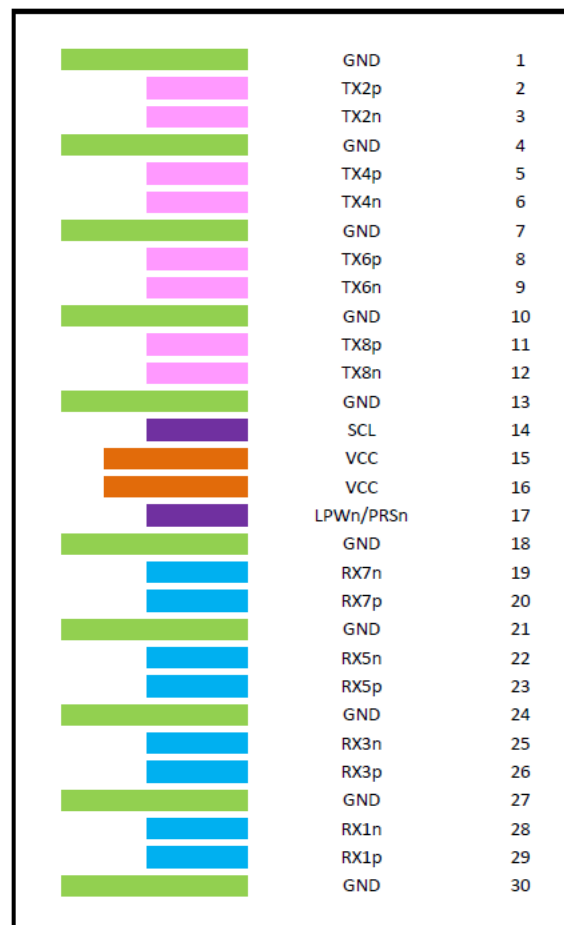

----- Module Card Edge -----

Figure 1 – OSFP module Pinout

PIN	Logic	Symbol	Name/Description
1		GND	Ground
2	CML-I	TX2p	Transmitter Data Non-Inverted
3	CML-I	TX2n	Transmitter Data Inverted
4		GND	Ground
5	CML-I	TX4p	Transmitter Data Non-Inverted

6	CML-I	TX4n	Transmitter Data Inverted
7		GND	Ground
8	CML-I	TX6p	Transmitter Data Non-Inverted
9	CML-I	TX6n	Transmitter Data Inverted
10		GND	Ground
11	CML-I	TX8p	Transmitter Data Non-Inverted
12	CML-I	TX8n	Transmitter Data Inverted
13		GND	Ground
14	LVC MOS-I/O	SCL	2-wire Serial interface clock
15		VCC	+3.3V Power
16		VCC	+3.3V Power
17	Multi-Level	LPWn/PRSn	Low-Power Mode / Module Present
18		GND	Ground
19	CML-O	RX7n	Receiver Data Inverted
20	CML-O	RX7p	Receiver Data Non-Inverted
21		GND	Ground
22	CML-O	RX5n	Receiver Data Inverted
23	CML-O	RX5p	Receiver Data Non-Inverted
24		GND	Ground
25	CML-O	RX3n	Receiver Data Inverted
26	CML-O	RX3p	Receiver Data Non-Inverted
27		GND	Ground
28	CML-O	RX1n	Receiver Data Inverted
29	CML-O	RX1p	Receiver Data Non-Inverted
30		GND	Ground
31		GND	Ground
32	CML-O	RX2p	Receiver Data Non-Inverted
33	CML-O	RX2n	Receiver Data Inverted
34		GND	Ground
35	CML-O	RX4p	Receiver Data Non-Inverted
36	CML-O	RX4n	Receiver Data Inverted
37		GND	Ground
38	CML-O	RX6p	Receiver Data Non-Inverted
39	CML-O	RX6n	Receiver Data Inverted
40		GND	Ground
41	CML-O	RX8p	Receiver Data Non-Inverted
42	CML-O	RX8n	Receiver Data Inverted
43		GND	Ground
44	Multi-Level	INT/RSTn	Module Interrupt / Module Reset
45		VCC	+3.3V Power
46		VCC	+3.3V Power

47	LVC MOS-I/O	SDA	2-wire Serial interface data
48		GND	Ground
49	CML-I	TX7n	Transmitter Data Inverted
50	CML-I	TX7p	Transmitter Data Non-Inverted
51		GND	Ground
52	CML-I	TX5n	Transmitter Data Inverted
53	CML-I	TX5p	Transmitter Data Non-Inverted
54		GND	Ground
55	CML-I	TX3n	Transmitter Data Inverted
56	CML-I	TX3p	Transmitter Data Non-Inverted
57		GND	Ground
58	CML-I	TX1n	Transmitter Data Inverted
59	CML-I	TX1p	Transmitter Data Non-Inverted
60		GND	Ground

1.6 Mechanical Specifications

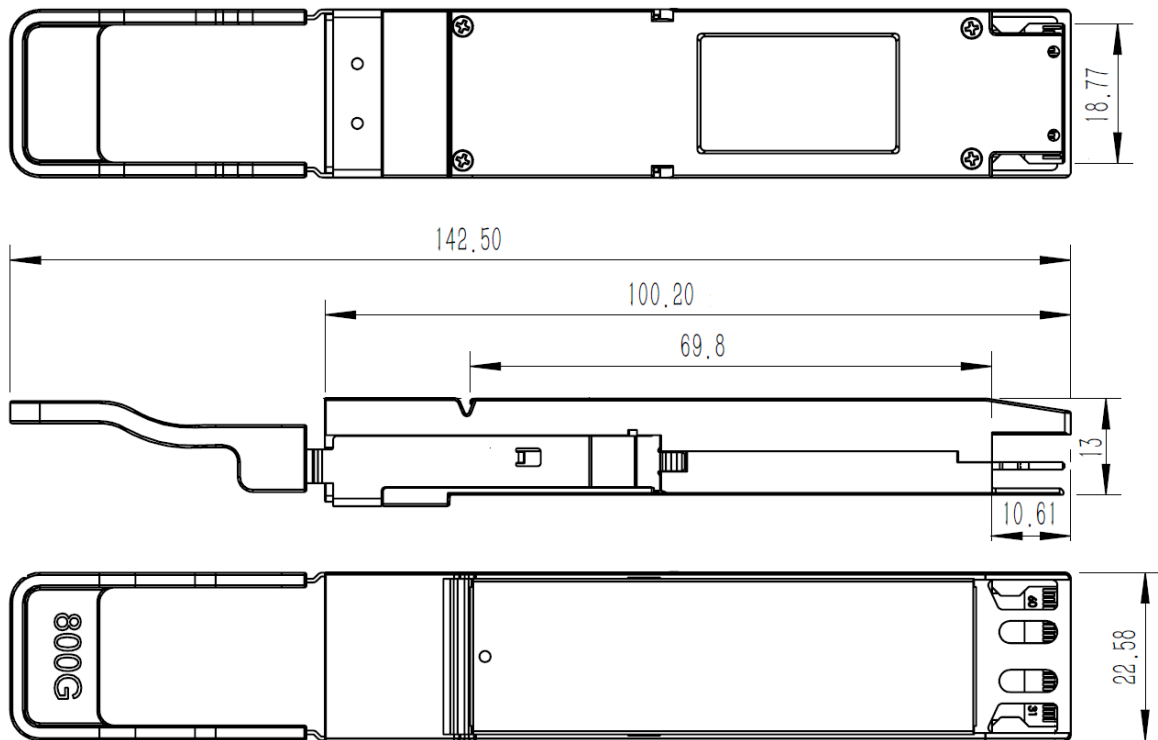

Figure 2 – Mechanical Dimensions

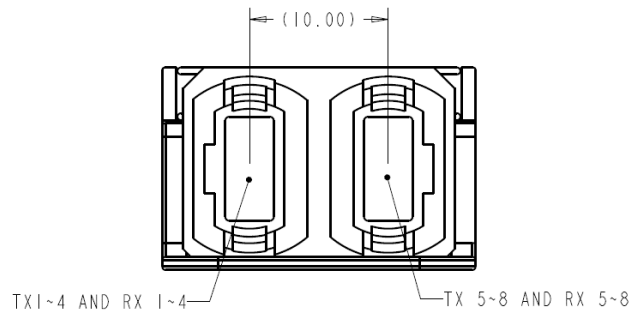

Figure 3 – Active fiber ports in MPO12 connector on module side

2.0 Product Information

Data Rate	Factor		Optical	Wavelength	Reach
800G	OSFP	SR8	MPO	850nm	70m

ESD Safety Cautions

This transceiver is specified as ESD threshold 1KV for high speed data pins based on Human Body Model per ANSI/ESDA/JEDECJS-001. The units are subjected to 15kV air discharges during operation and 8kV direct contact discharges to the case. However, normal ESD precautions are still required during the handling of this module. This transceiver is shipped in ESD protective packaging. It should be removed from the packaging and handled only in an ESD protected environment.

Important Notice

The performance figures, data, and any illustrative material presented in this datasheet are typical and must be explicitly confirmed in writing by ZHAOLONG before they are deemed applicable to any specific order or contract.

By ZHAOLONG's policy of continuous improvement, specifications may change without prior notice. The publication of information in this datasheet does not imply exemption from patent or other protective rights held by ZHAOLONG or other parties. Additional details can be obtained from any ZHAOLONG sales representative.

3.0 Revision Record

Rev.	Comments	Author	Date
A01	Initial Release	Koko Sun	10/01/2023
